

HIGH PERFORMANCE DATA DETECTION TECHNIQUES FOR MASSIVE MIMO SYSTEM WITH LOW COMPLEXITY

HARIHARAN¹, A. SARAVANAN²

¹PG Scholar, VLSI Design, Department of ECE, Mahabarathi Engineering College, India.

²Assistant professor, Department of ECE, Mahabarathi Engineering College, India

Abstract

In this paper we propose a massive MIMO system with coordinate descent (CD)-based data detector for orthogonal frequency division multiplexing (OFDM). Signal detection in massive multi-user (MU) multiple input multiple-output (MIMO) environments are the most difficult tasks due to the excessive computation and diversity inclusions. In this paper, the efficiency of two well established equalization-based soft-output data-detection algorithm and corresponding FPGA implementation for wideband massive MU-MIMO systems that use orthogonal frequency-division multiplexing (OFDM) is analyzed. Here we carried out two systems as follows: approximate minimum mean square error (MMSE) and box-constrained equalization using coordinate descent. Some algorithm-level optimizations are used to get near-optimal error-rate performance at low implementation complexity, even with more number of base-station (BS) antennas and thousands of subcarriers. And finally reference FPGA design is carried out for massive MU-MIMO-OFDM systems for complexity analyzes and provides an extensive comparison to existing designs in terms of implementation complexity, throughput, and error-rate performance.

Index terms: MIMO, BS, MMSE.

1. Introduction

Next Generation (4G) communication networks, also known as Dynamic Spectrum Access Networks (DSANs) as well as cognitive radio networks will provide high bandwidth to mobile users via heterogeneous wireless architectures and dynamic spectrum access techniques. The inefficient usage of the existing spectrum can be improved through opportunistic access to the licensed bands without interfering with the existing users. 4G networks, however, impose several research challenges due to the broad range of available spectrum as well as diverse Quality-of-Service (QoS) requirements of applications. These heterogeneities must be captured and handled dynamically as mobile terminals roam between wireless architectures and along the available spectrum pool. The key enabling technology of 4G networks is the cognitive radio. Cognitive radio techniques provide the capability to use or share the spectrum in an opportunistic manner. Dynamic spectrum access techniques allow the cognitive radio to operate in the best available channel. More specifically, the cognitive radio technology will enable the users to (1) determine which portions of the spectrum is available and detect the presence of licensed users when a user operates in a licensed band (spectrum sensing), (2) select the best available channel (spectrum management), (3) coordinate access to this

channel with other users (spectrum sharing), and (4) vacate the channel when a licensed user is detected (spectrum mobility).

Every wireless system has to combat transmission and propagation effects that are substantially more hostile than for a wired system. In the early days of wireless telegraphy, Marconi successfully demonstrated that wireless signals can cross the Atlantic and Pacific Oceans. Today, the role of radio has changed: we are not using radio technology merely to cover large distances, but rather for its flexibility and comfort. Short-range wireless links provide access to the fixed telecommunication infrastructure. Critical technical bottlenecks in a wireless link are the capacity of the radio channel, its unreliability due to adverse time-varying, multipath propagation and severe interference from other transmissions, in neighbouring cells. Unless specific measures are taken, substantial fade margins are needed, in addition to the C/I or C/N protection ratio used in a stationary (non-varying) channel.

In telecommunications, 4G is the fourth generation of cellular wireless standards. It is a successor to 3G and 2G families of standards. Speed requirements for 4G service set the peak download speed at 100 Mbit/s for high mobility communication (such as from trains and cars) and 1 Gbit/s for low mobility communication (such as pedestrians and stationary users). A 4G system is expected to provide a comprehensive and secure all-IP based mobile broadband solution to laptop computer wireless modems, smart phones, and other mobile devices. Facilities such as ultra-broadband Internet access, IP telephony, gaming services, and streamed multimedia may be provided to users. Pre-4G technologies such as mobile WiMAX and first-release 3G Long term evolution (LTE) have been on the market since 2006 and 2009 respectively, and are often branded as 4G. The current versions of these technologies did not fulfill the original ITU-R requirements of data rates approximately up to 1 Gbit/s for 4G systems. Marketing materials use 4G as a description for Mobile-WiMAX and LTE in their current forms.

IMT-Advanced compliant versions of the above two standards are under development and called "LTE Advanced" and "Wireless MAN-Advanced" respectively. ITU has decided that "LTE Advanced" and "Wireless MAN-Advanced" should be accorded the official designation of IMT-Advanced. On December 6, 2010, ITU announced that current versions of LTE, WiMax and other evolved 3G technologies that do not fulfill "IMT-Advanced" requirements could be considered "4G", provided they represent forerunners to IMT-Advanced and "a substantial level of improvement in performance and capabilities with respect to the initial third generation systems now deployed." In all suggestions for 4G, the CDMA spread spectrum radio technology used in 3G systems and IS-95 is

abandoned and replaced by OFDM and other frequency-domain equalization schemes. This is combined with MIMO (Multiple In Multiple Out), e.g., multiple antennas, dynamic channel allocation and channel-dependent scheduling.

2. Related Work

In the choice of a digital modulation schemes in a mobile radio system by P. S. Mundra, T. L. Singal and R. Kapur [1], described the emerging modulation technologies in the family of linear modulation and constant envelope techniques of digital modulation. Both of these techniques have been used extensively in mobile communication systems. The selection of one over the other depends on the priorities set in the system requirements. If most efficient bandwidth utilization and moderate hardware complexity is the key note – QPSK will be a better choice. Whereas continuous phase modulation schemes offer constant envelope, narrow power spectra, good error rate performance, etc. non-linear power amplifiers are important features and compromise in channel separation is permissible and higher circuit complexity is of less consideration. Spectral efficiency can be further improved by using suitable coding techniques.

W. A. C. Fernando, R.M.A.P. Rajatheva and K. M. Ahmed [2] proposed a novel technique for the performance of coded OFDM with higher modulation schemes. Higher modulation schemes with OFDM for a Rician fading channel with two frequency bands are considered by W.A.C. Fernando. Rectangular QAM and 8-PSK constellation modulation schemes are considered with convolution coding and TCM. Coding gain is considered at two different values of BER. It has been shown that there is no significant difference of BER performance between two frequency bands considered. BER slope is high for OFDM for high SNR values whereas, MIMO OFDM performance seems to be better compared to OFDM by considering the fact that TCM code has a lower trellis size.

A bit and power allocation strategy for AMC based spatial multiplexing MIMO-OFDM systems is studied by M. S. Al-Janabi, C. C. Tsimenidis, B. S. Sharif and S. Y. Le Goff [3]. This strategy aims to maximize the average system throughput by allocating the available resources optimally among the utilized bands depending on the corresponding channel conditions and the total transmission power constraints. The average system throughput is represented as a trade-off criterion between the spectral efficiency and BER. The considered AMC technique utilizes distinct modulation and coding scheme (MCS) options rather than adopting fixed or uncoded approaches. The transmitter divides the OFDM frame at each transmit antenna into bands depending on the number of active users in an assigned base station (BS). The simulation results show superior performance of the MIMO-AMC-OFDM system, which adopts the proposed strategy, over other conventional schemes.

The performance of a LTE system with two transmits antennas and two receive antennas in a frequency selective fading environment was focussed by S. Ajey, B.Srivalli and G.V.Rangaraj [4]. 4G wireless systems predominately employ MIMO with an OFDM system. Like other 4G systems LTE also employs MIMO-OFDM physical layer. MIMO helps in increasing the throughput whereas OFDM converts a frequency selective fading channel to multiple flat fading sub-

channels facilitating easy equalization. It is proposed that LTE system should mandatorily support 2x2 MIMO setup. The performance of the MIMO system is better than that of a single antenna based system either in terms of performance (diversity) or throughput as in the case of transmit diversity or spatial multiplexing respectively.

3. Proposed Method

Orthogonal Frequency Division Multiple Access (OFDM) is a cellular air interface used in 4G communications networks such as WiMAX and LTE, based on OFDM for multiple, simultaneous users. OFDM has several benefits ranging from increased flexibility to improved throughput and robustness. By assigning sub-channels to specific subscribers, transmissions from several subscribers can occur simultaneously without interfering, thus minimizing an effect known as Multiple Access Interference (MAI). But we can't support all the users with this throughput. It is not sufficient when number of subscribers is increased in everyday. So the massive MIMO is used to increase the throughput without increasing the channel capacity. So the massive MIMO technique is used with OFDM to increase the data rate further with the same available spectrum. 4G seems to be the solution for the growing user requirements of wireless broadband access and the limitations of the existing wireless communication system.

MIMO is an antenna technology which uses multiple channels in radios to provide the functions of both the transmitter and receiver of data signals sent over the network. It provides high spectral efficiency and link reliability facilitating significant increase in the data throughput and radio link usage without additional bandwidth and transmission power. This high efficiency is due to the availability of an independent path in a rich scattering environment for each transmitter and receiver antennas in the radio.

The MIMO channels can be used with OFDMA for transmission and reception of modulated signal over network to single or multiple users. This is currently used in WLAN – Wi-Fi 802.11n, Mesh Networks (e.g., WMAN– WiMAX 802.16e, RFID, and Digital Home). Multi-user – MIMO (MU-MIMO) is the variant antenna technology that enhances the communication capabilities of the individual radio terminal used by radios in the network by introducing multiple independent radio terminals. This allows transmission and reception to and from multiple users using the same band.

The MIMO technique does not require any bandwidth expansions or any extra transmission power. Therefore, it provides a promising means to increase the spectral efficiency of a system. In his paper about the capacity of multi-antenna Gaussian channels, Telatar showed that given a wireless system employing N_t TX (transmit) antennas and N_r RX (receive) antennas, the maximum data rate at which error-free transmission over a fading channel is theoretically possible is proportional to the minimum of N_t and N_r (provided that the $N_t N_r$ transmission paths between the TX and RX antennas are statistically independent). Hence huge throughput gains may be achieved by adopting $N_t \times N_r$ MIMO systems compared to conventional 1×1 systems that use single antenna at both ends of the link with the same requirement of power and bandwidth. With multiple antennas, a new domain, namely, the spatial

domain is explored, as opposed to the existing systems in which the time and frequency domain are utilized. The bottleneck problem of complexity for channel estimation in MIMO-OFDM systems has been studied by two different approaches. The first one shortens the sequence of training symbols to the length of the MIMO channel, leading to orthogonal structure for preamble design. Its drawback lies in the increase of the overhead due to the extra training OFDM blocks.

The block diagram of a MIMO-OFDM system is shown in Figure 1. Basically, the MIMO-OFDM transmitter has N_t parallel transmission paths which are very similar to the single antenna OFDM system, each branch performing serial-to-parallel conversion, pilot insertion, N -point IFFT and cyclic extension before the final TX signals are up-converted to RF and transmitted. It is worth noting that the channel encoder and the digital modulation, in some spatial multiplexing systems can also be done per branch, not necessarily implemented jointly over all the N_t branches. The receiver first must estimate and correct the possible symbol timing error and frequency offsets, e.g., by using some training symbols in the preamble.

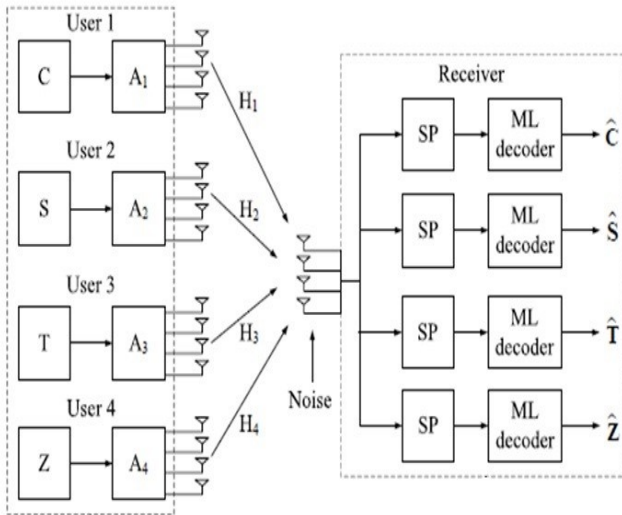

Figure 1: MU MIMO block diagram

Subsequently, the CP is removed and N -point FFT is performed per receiver branch. In this thesis, the channel estimation algorithm we proposed is based on single carrier processing that implies MIMO detection [5] has to be done per OFDM subcarrier. Therefore, the received signals of subcarrier k are routed to the k th MIMO detector to recover all the N_t data signals transmitted on that subcarrier. Next, the transmitted symbol per TX antenna is combined and outputted for the subsequent operations like digital demodulation and decoding. Finally all the input binary data are recovered with certain BER. As a MIMO signalling technique, N_t different signals are transmitted simultaneously over $N_t \times N_r$ transmission paths and each of those N_r received signals is a combination of all the N_t transmitted signals and the distorting noise. It brings in the diversity gain for enhanced system capacity as we desire. Meanwhile compared to the SISO system, it complicates the system design regarding to channel

estimation and symbol detection due to the hugely increased number of channel coefficients.

4. Equalization-Based Data Detection

The performance sacrifice associated with this modulation scheme compared with coherent modulation schemes is often motivated by its simple receiver structure and its avoidance of pilot symbols. However, if the subcarriers are coherently modulated as in the DVB standard, estimation of the channel's attenuations of each subcarrier is necessary. These estimates are used in the channel equalizer, which, in an OFDM receiver, may consist of one complex multiplication for each subcarrier in an OFDM symbol. Channel estimation in OFDM is usually performed with the aid of pilot symbols. Since each subcarrier is flat fading, techniques from single-carrier flat fading systems are directly applicable to OFDM. For such systems pilot-symbol assisted modulation (PSAM) on flat fading channels involves the sparse insertion of known pilot symbols in a stream of data symbols. The attenuation of the pilot symbols is measured and the attenuations of the data

symbols in between these pilot symbols are typically estimated/interpolated using time-correlation properties of the fading channel.

The concept of PSAM in OFDM systems also allows the use of the frequency correlation properties of the channel. The first pilot pattern inserts entirely known OFDM symbols in the OFDM signal. The second modulates pilot symbols on a particular set of subcarriers. The third pattern uses scattered pilot symbols, as in the DVB standard. In OFDM systems where Doppler effects are kept small (that is, the OFDM symbol is short compared with the coherence time of the channel) the time correlation between the channel attenuations of consecutive OFDM symbols is high. Furthermore, in a properly designed OFDM system the subcarrier spacing is small compared with the coherence bandwidth of the channel.

Where the diagonal matrix \mathbf{X} contains the transmitted symbols on its diagonal (either known pilot symbols or receiver decisions of information symbols which we in the following assume are correct), and the vector \mathbf{Y} contains the observed outputs of the DFT. In this matrix notation the least-

squares (LS) channel estimate (minimizing $\|\mathbf{y} - \mathbf{X}\hat{\mathbf{h}}\|^2$ for all possible $\hat{\mathbf{h}}$) becomes

$$\hat{\mathbf{h}}_{LS} = \mathbf{X}^{-1} \mathbf{y} = \begin{bmatrix} y_0 & y_1 & \dots & y_{N-1} \\ x_0 & x_1 & \dots & x_{N-1} \end{bmatrix}^T$$

This estimator simply divides the received symbol on each subcarrier by the transmitted symbol to obtain an estimate of the channel attenuation. From the system property, this is an estimator that intuitively makes sense. The frequency correlation can now be used to smooth and improve the LS channel estimate. Various strategies can be adopted to use the frequency correlation. The optimal linear minimum mean-

squared error (LMMSE) estimate of \mathbf{h} (minimizing $E\{\|\hat{\mathbf{h}} - \mathbf{h}\|^2\}$ for all possible linear estimators $\hat{\mathbf{h}}$) becomes $\hat{\mathbf{h}}_{\text{LMMSE}} = \mathbf{A}\hat{\mathbf{h}}_{\text{LS}}$, (26)

Where

$$\mathbf{A} = \mathbf{R}_{\hat{\mathbf{h}}_{\text{LS}}\hat{\mathbf{h}}_{\text{LS}}}^{-1} \mathbf{R}_{\hat{\mathbf{h}}_{\text{LS}}\mathbf{h}} = \mathbf{R}_{\hat{\mathbf{h}}_{\text{LS}}\mathbf{h}} \left(\mathbf{R}_{\mathbf{h}\mathbf{h}} + \sigma_n^2 (\mathbf{X}\mathbf{X}^H)^{-1} \right)^{-1}$$

and $\mathbf{R}_{\mathbf{h}\mathbf{h}} = E\{\mathbf{h}\mathbf{h}^H\}$ is the channel autocorrelation matrix, that is, the matrix containing the correlations of the channel attenuations of the subcarriers. Similarly, $\mathbf{R}_{\hat{\mathbf{h}}_{\text{LS}}\hat{\mathbf{h}}_{\text{LS}}}$ denotes the correlation matrix between the channel attenuations and their LS-estimates, and $\mathbf{R}_{\hat{\mathbf{h}}_{\text{LS}}\mathbf{h}}$ denotes the auto correlation matrix of the LS estimates.

This LMMSE estimator is, for complexity reasons, of little practical value. Not only does it assume knowledge of the channel correlation and the SNR, it also requires many multiplications per estimated attenuation, and the dependency on the pilots or decisions may require frequent recalculation of the matrix. However, the LMMSE estimator (or any other high-performance and complex estimator) can be used as a basis for the design of more feasible estimators. Their performances can be made very close to that of the optimal LMMSE estimator. They are generic in the sense that they use assumed (fixed) channel correlation and SNR for the design of. They are low-complexity in the sense that they require significantly fewer than many multiplications per estimated attenuation.

A) Spatial Separation Between Sources

The idea underlying this technology is to equip the base-station (BS) with hundreds of antenna elements while communicating with tens of user terminals concurrently and within the same time-frequency resource. However, the large dimensionality of the data detection problem faced in the uplink (where users communicate to the BS), results in excessively high implementation complexity at the BS. Hence, to reduce the implementation costs while enabling throughputs in the Gb/s regime for practical wideband massive MU-MIMO systems with hundreds of antenna elements and thousands of subcarriers, novel algorithms and dedicated hardware implementations on field-programmable gate arrays (FPGAs). In physics, interference is the phenomenon in which two waves superpose each other to form a resultant wave of greater or lower amplitude. Interference usually refers to the interaction of waves that are correlated or coherent with each other, either because they come from the same source or because they have the same or nearly the same frequency.

This form of interference can occur whenever a wave can propagate from a source to a destination by two or more paths of different lengths. Two or more sources can only be used to produce interference when there is a fixed phase relation between them, but in this case the interference generated is the same as with a single source; see Huygens' principle.

B) Space Time Coding For MIMO-OFDM

A space-time code (STC) is a method employed to improve the reliability of data transmission in wireless communication systems using multiple transmit antennas. STCs rely on transmitting multiple, redundant copies of a data stream to the receiver in the hope that at least some of them may survive the physical path between transmission and reception in a good enough state to allow reliable decoding. Space time codes may be split into two main types: Space time trellis codes (STTCs) distribute a trellis code over multiple antennas and multiple time-slots and provide both coding gain and diversity gain. Space time block code (STBC) act on a block of data at once (similarly to block codes) and provide only diversity gain, but are much less complex in implementation terms than STTCs.

The MIMO channel matrix H corresponding to n_t transmit antennas and n_r receive antennas can be represented by an $n_r \times n_t$ matrix:

$$\mathbf{H} = \begin{pmatrix} h_{t1,1} & h_{t1,2} & \dots & h_{t1,n_t} \\ h_{t2,1} & h_{t2,2} & \dots & h_{t2,n_t} \\ \dots & \dots & \dots & \dots \\ h_{t n_r,1} & h_{t n_r,2} & \dots & h_{t n_r,n_t} \end{pmatrix}$$

Where the ji -th element, denoted by $h_{t,j,i}$, is the fading gain coefficient for the path from transmit antenna i to receive antenna j . We assume perfect channel knowledge at the receiver side and the transmitter has no information about the channel available at the transmitter side. Given the receive matrix Y the ML-detector decides for the transmit matrix S with smallest Euclidian distance d_2 . The structure of the MIMO solution is very similar to that of a conventional wireless OFDM physical layer, except that the carrier frequency is changed based on the time-frequency code. In addition, other modifications have been made to reduce the area and size.

Multiuser orthogonal frequency-division multiplexing (MB-OFDM) is one of ultra-wideband (UWB) radio standards, which provides high-speed connectivity in a wireless personal area network (PAN) with specification of the data rates from 53.3 to 480 Mbps. Due to the high data rates, the MB-OFDM standard requires to process large amount of computations in very short time; its modem has to compute one symbol that consists of 165 complex numbers in every 312.5 ns. Even though its performance requirement results in large hardware complexity, a low power design with small chip size is absolutely essential for applying this technology to portable handheld devices.

4. EXPERIMENTAL RESULTS

Based on those assumptions such as perfect synchronization and block fading, we end up with a compact and simple signal model for both the single antenna OFDM and MIMO-OFDM systems. Surely it is an ideal model that says, considering first a noise free scenario, the received signal on the k -th subcarrier is just a product (or matrix product for MIMO case) of the transmitted signal on the k -th subcarrier and the discrete-time channel frequency response at the k -th subcarrier.

Noise in frequency domain can also be modeled as an additive term. When it comes to channel estimation for OFDM systems, this model is still valid since there is no ICI as we assume. For channel estimation of MIMO-OFDM systems, it is appropriate to estimate the channel in time domain rather than in frequency domain because there are few parameters in the impulse response ($N_t N_r L$ coefficients) than in the frequency response ($N_t N_r N$ coefficients). Given the limited number of training data that can be sent to estimate the fast time-varying channel, limiting the number of parameters to be estimated would increase the accuracy of the estimation.

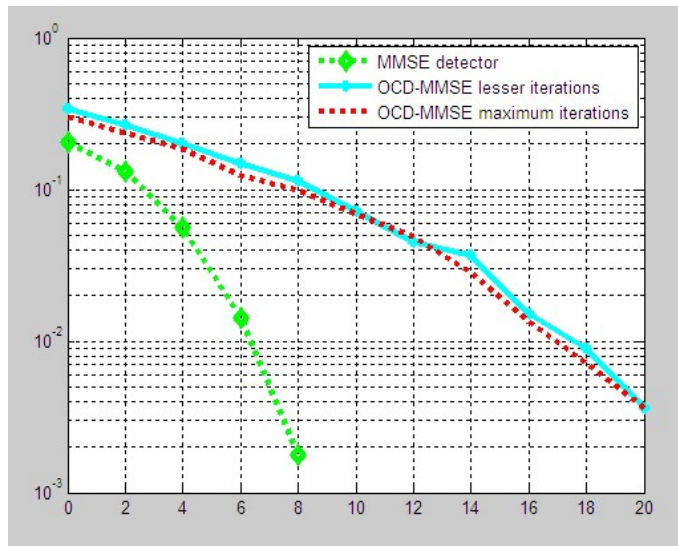

Figure 2: BER performance of massive MIMO using 32 BS antennas

Finding the optimal MMSE precoding is often difficult, leading to approximate approaches that concentrate on either the numerator or denominator of the mentioned ratio; that is, maximum ratio transmission (MRT) and zero-forcing (ZF) precoding. MRT only maximizes the signal gain at the intended user. MRT is close-to-optimal in noise-limited systems, where the co-user interference is negligible compared to the noise. ZF precoding aims at nulling the co-user interference, at the expense of losing some signal gain. ZF precoding can achieve close to the system capacity when the number of users is large or the system is interference-limited (i.e., the noise is weak compared to the interference). If receivers have multiple antennas, then regularized zero-forcing precoding has the corresponding properties.

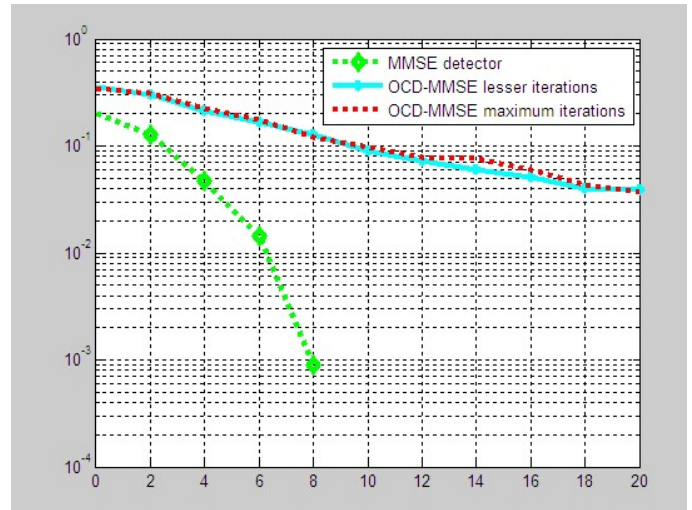

Figure 3: BER performance of MIMO over maximum BS using 64 BS antennas

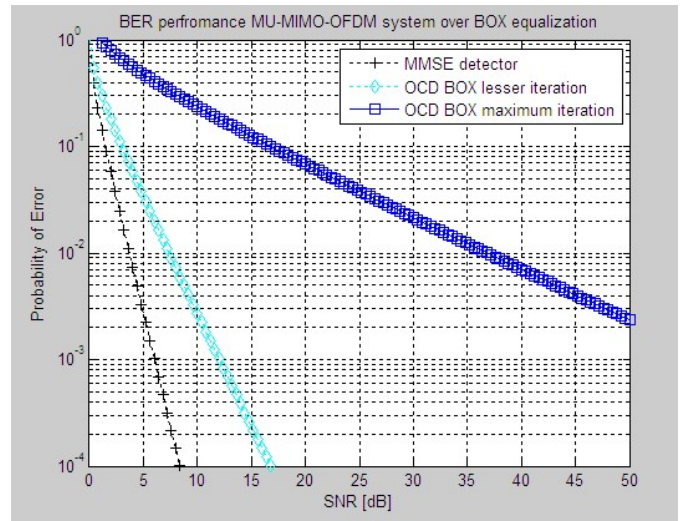

Figure 4: Box equalizer metrics over OCD

Multi-user MIMO can leverage multiple users as spatially distributed transmission resources, at the cost of somewhat more expensive signal processing. In comparison, conventional, or single-user MIMO considers only local device multiple antenna Dimensions. Multi-user MIMO algorithms are developed to enhance MIMO systems when the number of users, or connections, numbers greater than one (admittedly, a useful concept). Table 1 shows the maximum speed of the slow corner in the channel estimation method. Speed is defined as how fast the device or hardware runs. The maximum speed of the slow corner is 455.79MHz. From the Table 1, the experimental evaluation shows that the total logic elements in the existing system are 3197 and in the proposed system the total logic elements is reduced to 2325. On comparing both the existing and proposed system the overall area is reduced. Table 1: Massive MIMO system Performance Report with QUARTUS II Hardware Synthesis Using CYCLONE II Family (EP2C35F672C6).

TYPE	SPEED	AREA
MMSE OCD	104.74MHz	2325 total logic elements
Existing method	49.56MHz	3197 total logic elements

5. Conclusion

The major advantage of MIMO-based systems in LTE-Advanced over existing standard wireless networks is the channel state information feedback to the transmitter and with the combination of increased range various modulation schemes at a given distance. In this paper we analyze the performance of massive MIMO with coordinate descent (CD)-based data detector for orthogonal frequency division multiplexing (OFDM). As a result of the use of multiple antennas, high-performance linear MMSE and nonlinear box-constrained data detection are considerably increasing the Quality of service of a given channel. By increasing the number of bits mapped (mapping order) and number of antennas it is possible to get same QoS through spatial diversity with every pair of antennas added to the system. Hardware synthesis results shows that OCD provides OFDM-based massive MU-MIMO systems at low implementation costs.

7. References

- [1] P. S. Mundra , T. L. Singal and R. Kapur, "The Choice of A Digital Modulation ,Schemes in A Mobile Radio System", IEEE 1993,ISSN 1090-3038.
- [2] W. A. C. Fernando, R.M.A.P. Rajatheva and K. M. Ahmed, "Performance of Coded OFDM with Higher Modulation Schemes", IEEE Oct 1998, Communication technology proceedings dated 10.110.
- [3] M. S. Al-Janabi, C. C. Tsimenidis, B. S. Sharif and S. Y. Le Goff, "Bit and Power Allocation Strategy for AMC-based MIMO-OFDM WiMAX Systems", IEEE dated 2010.5645007 Wireless and mobile computing.
- [4] S. Ajey, B.Srivalli and G.V.Rangaraj, "On Performance of MIMO-OFDM Based LTE Systems", IEEE Ddated 2010.5415899, ICWCSC 2010 Wireless communication and sensor computing.
- [5] E. G. Larsson, O. Edfors, F. Tufvesson, and T. L. Marzetta, "Massive MIMO for next generation wireless systems," IEEE Commun. Mag., vol. 52, no. 2, pp. 186–195, Feb. 2014.